

Ultralow V_F Ultrafast Rectifier, 8 A FRED Pt[®]



2L TO-220AC



2L TO-220 FULL-PAK

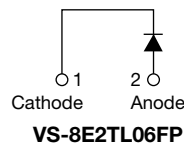
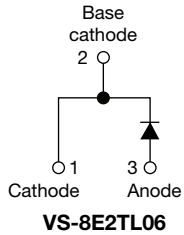

FEATURES

- Ultrafast recovery time, extremely low V_F and soft recovery
- 175 °C maximum operating junction temperature
- For PFC DCM operation
- True 2 pin package
- Low leakage current
- Fully isolated package ($V_{INS} = 2500 V_{RMS}$)
- Compliant to RoHS directive 2002/95/EC
- Halogen-free according to IEC 61249-2-21 definition
- Designed and qualified for industrial level



RoHS
COMPLIANT
HALOGEN
FREE
Available

DESCRIPTION

State of the art, ultralow V_F , soft-switching ultrafast rectifiers optimized for Discontinuous (Critical) Mode (DCM) Power Factor Correction (PFC).

The minimized conduction loss, optimized stored charge and low recovery current minimize the switching losses and reduce over dissipation in the switching element and snubbers.

The device is also intended for use as a freewheeling diode in power supplies and other power switching applications.

APPLICATIONS

AC/DC SMPS 70 W to 400 W
e.g. laptop and printer AC adaptors, desktop PCs, TVs and monitors, games units and DVD ac-to-dc power supplies.

PRODUCT SUMMARY

Package	2L TO-220AC, 2L TO-220 FP
$I_{F(AV)}$	8 A
V_R	600 V
V_F at I_F	1.07 V
t_{rr} (typ.)	60 ns
T_J max.	175 °C
Diode variation	Single die

ABSOLUTE MAXIMUM RATINGS

PARAMETER	SYMBOL	TEST CONDITIONS	VALUES	UNITS
Peak repetitive reverse voltage	V_{RRM}		600	V
Average rectified forward current	$I_{F(AV)}$	$T_C = 156\text{ °C}$	8	A
		$T_C = 131\text{ °C}$		
Non-repetitive peak surge current	I_{FSM}	$T_J = 25\text{ °C}$	125	
Peak repetitive forward current	I_{FM}		16	
Operating junction and storage temperatures	T_J, T_{Stg}		- 65 to 175	°C

ELECTRICAL SPECIFICATIONS ($T_J = 25\text{ °C}$ unless otherwise specified)

PARAMETER	SYMBOL	TEST CONDITIONS	MIN.	TYP.	MAX.	UNITS
Breakdown voltage, blocking voltage	V_{BR}, V_R	$I_R = 100\ \mu A$	600	-	-	V
Forward voltage	V_F	$I_F = 8\text{ A}$	-	1	1.07	
		$I_F = 8\text{ A}, T_J = 150\text{ °C}$	-	0.85	0.90	
Reverse leakage current	I_R	$V_R = V_R$ rated	-	0.04	4	μA
		$T_J = 150\text{ °C}, V_R = V_R$ rated	-	10	70	
Junction capacitance	C_T	$V_R = 600\text{ V}$	-	6	-	pF
Series inductance	L_S	Measured lead to lead 5 mm from package body	-	8	-	nH

VS-8E2TL06-E, VS-8E2TL06-M, VS-8E2TL06FP-E



Vishay Semiconductors Ultralow V_F Ultrafast Rectifier,
8 A FRED Pt®

DYNAMIC RECOVERY CHARACTERISTICS ($T_J = 25\text{ }^\circ\text{C}$ unless otherwise specified)						
PARAMETER	SYMBOL	TEST CONDITIONS	MIN.	TYP.	MAX.	UNITS
Reverse recovery time	t_{rr}	$I_F = 1.0\text{ A}$, $di_F/dt = 100\text{ A}/\mu\text{s}$, $V_R = 30\text{ V}$	-	60	100	ns
		$I_F = 8.0\text{ A}$, $di_F/dt = 100\text{ A}/\mu\text{s}$, $V_R = 30\text{ V}$	-	150	250	
		$T_J = 25\text{ }^\circ\text{C}$	-	200	-	
		$T_J = 125\text{ }^\circ\text{C}$	-	255	-	
Peak recovery current	I_{RRM}	$T_J = 25\text{ }^\circ\text{C}$	-	15	-	A
		$T_J = 125\text{ }^\circ\text{C}$	-	20	-	
Reverse recovery charge	Q_{rr}	$T_J = 25\text{ }^\circ\text{C}$	-	1.5	-	μC
		$T_J = 125\text{ }^\circ\text{C}$	-	2.4	-	

THERMAL - MECHANICAL SPECIFICATIONS						
PARAMETER	SYMBOL	TEST CONDITIONS	MIN.	TYP.	MAX.	UNITS
Maximum junction and storage temperature range	T_J, T_{Stg}		- 65	-	175	$^\circ\text{C}$
Thermal resistance, junction to case	R_{thJC}		-	2	2.4	$^\circ\text{C}/\text{W}$
FULL-PAK			-	5	5.5	
Thermal resistance, junction to ambient per leg	R_{thJA}	Typical socket mount	-	-	70	
Typical thermal resistance, case to heatsink	R_{thCS}	Mounting surface, flat, smooth and greased	-	0.5	-	
Weight			-	2	-	g
			-	0.07	-	oz.
Mounting torque			6 (5)	-	12 (10)	kgf · cm (lbf · in)
Marking device		Case style TO-220	8E2TL06			
		Case style TO-220 FULL-PAK	8E2TL06FP			



VS-8E2TL06-E, VS-8E2TL06-M, VS-8E2TL06FP-E

Ultralow V_F Ultrafast Rectifier,
8 A FRED Pt[®]

Vishay Semiconductors

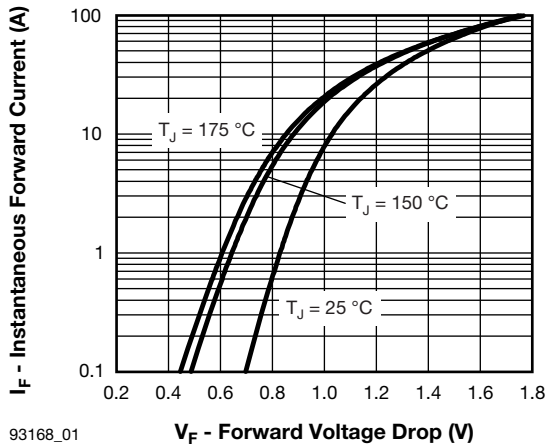

Fig. 1 - Typical Forward Voltage Drop Characteristics

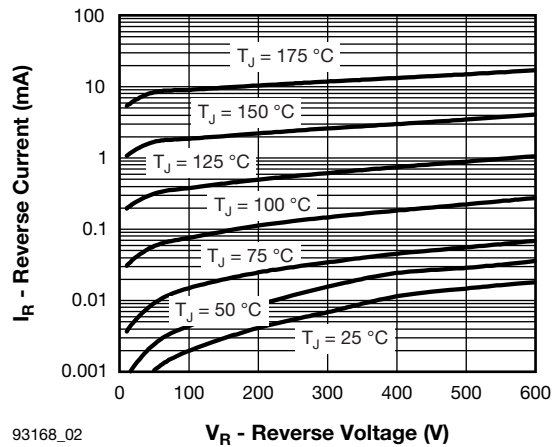

Fig. 2 - Typical Values of Reverse Current vs. Reverse Voltage

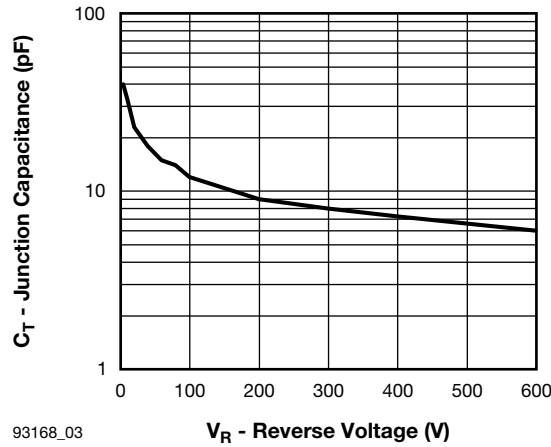

Fig. 3 - Typical Junction Capacitance vs. Reverse Voltage

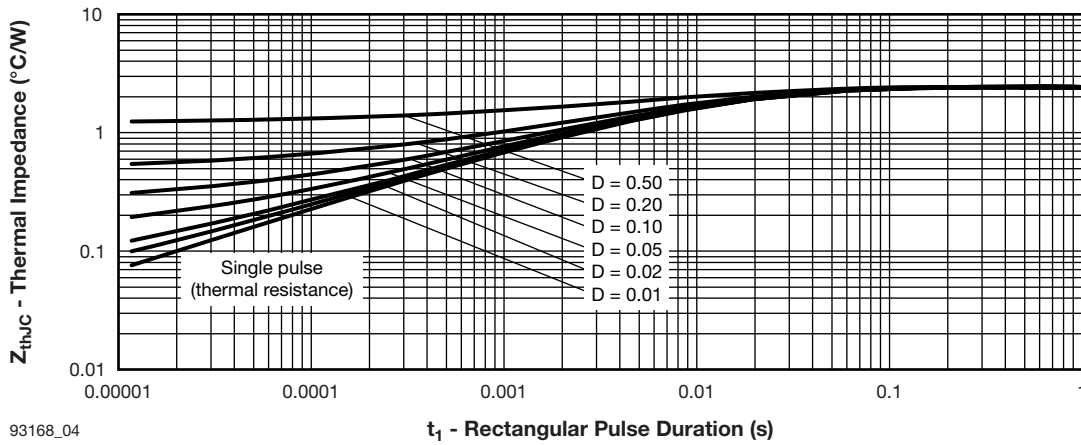

Fig. 4 - Maximum Thermal Impedance Z_{thJC} Characteristics (TO-220)

VS-8E2TL06-E, VS-8E2TL06-M, VS-8E2TL06FP-E



Vishay Semiconductors

Ultralow V_F Ultrafast Rectifier,
8 A FRED Pt®

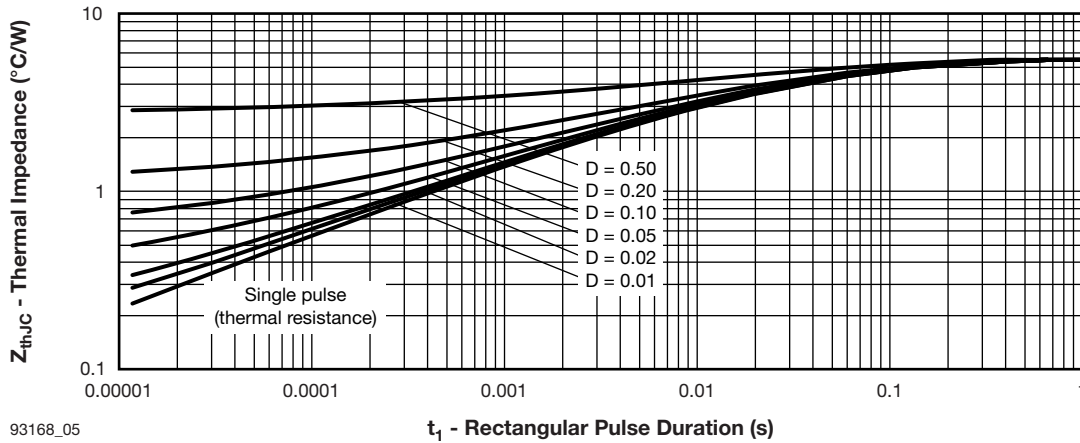

93168_05

Fig. 5 - Maximum Thermal Impedance Z_{thJC} Characteristics (FULL-PAK)

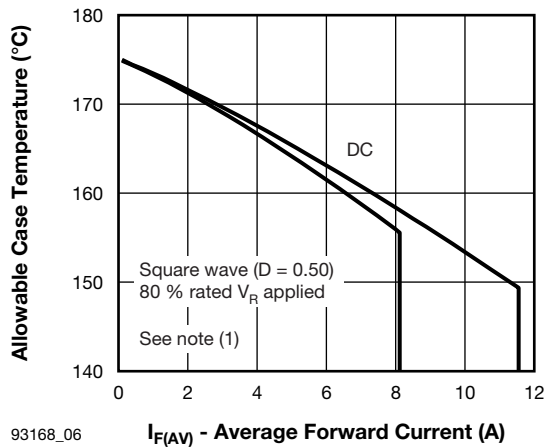

93168_06

Fig. 6 - Maximum Allowable Case Temperature vs. Average Forward Current (TO-220)

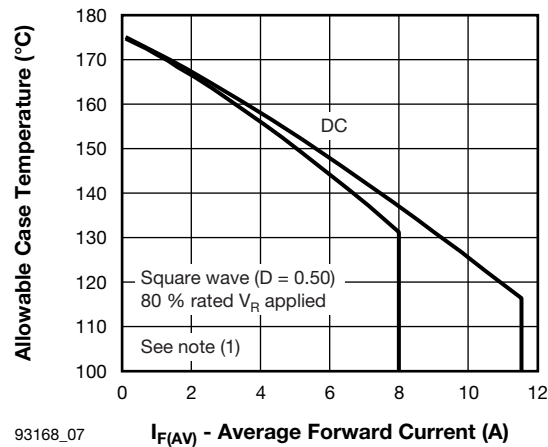

93168_07

Fig. 7 - Maximum Allowable Case Temperature vs. Average Forward Current (FULL-PAK)

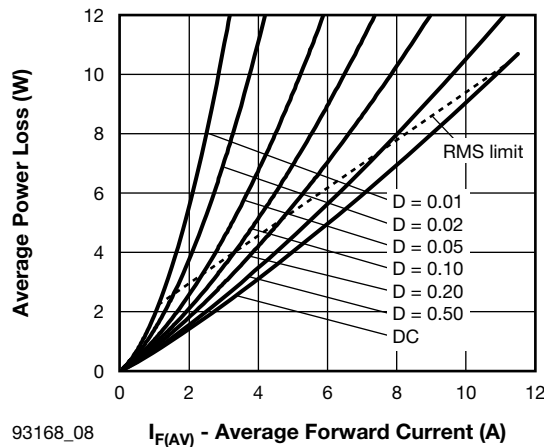

93168_08

Fig. 8 - Forward Power Loss Characteristics

Note

(1) Formula used: $T_C = T_J - (Pd + Pd_{REV}) \times R_{thJC}$; $Pd = \text{Forward power loss} = I_{F(AV)} \times V_{FM}$ at $(I_{F(AV)}/D)$ (see fig. 6); $Pd_{REV} = \text{Inverse power loss} = V_{R1} \times I_R (1 - D)$; I_R at $V_{R1} = \text{Rated } V_R$

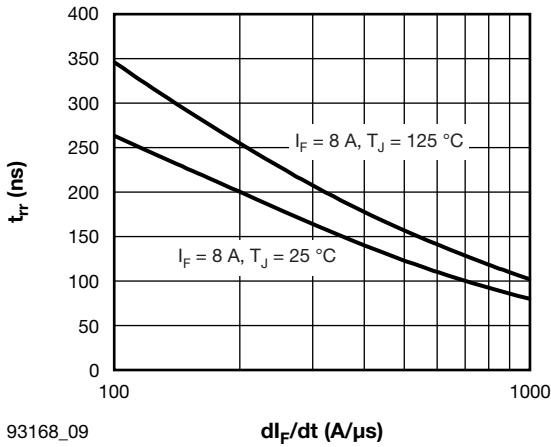

93168_09

Fig. 9 - Typical Reverse Recovery Time vs. di_F/dt

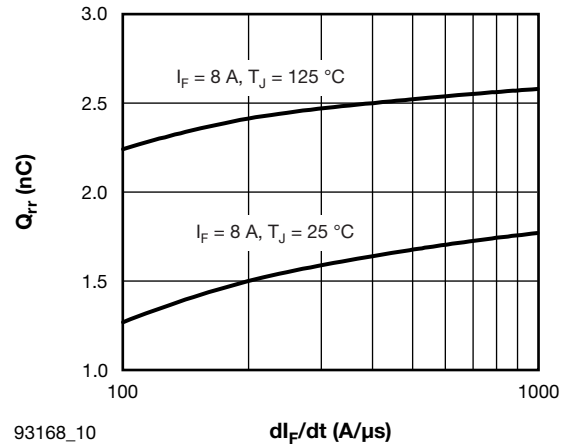

93168_10

Fig. 10 - Typical Stored Charge vs. di_F/dt

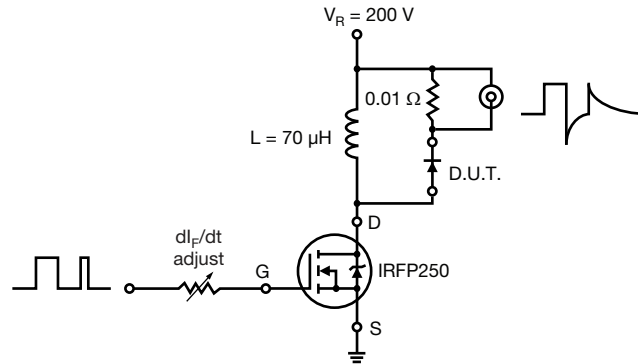
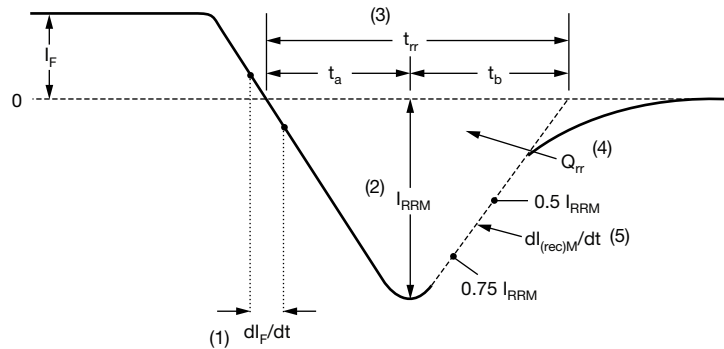

Fig. 11 - Reverse Recovery Parameter Test Circuit



(1) di_F/dt - rate of change of current through zero crossing

(2) I_{RRM} - peak reverse recovery current

(3) t_{rr} - reverse recovery time measured from zero crossing point of negative going I_F to point where a line passing through $0.75 I_{RRM}$ and $0.50 I_{RRM}$ extrapolated to zero current.

(4) Q_{rr} - area under curve defined by t_{rr} and I_{RRM}

$$Q_{rr} = \frac{t_{rr} \times I_{RRM}}{2}$$

(5) $dI_{(rec)M}/dt$ - peak rate of change of current during t_b portion of t_{rr}

Fig. 12 - Reverse Recovery Waveform and Definitions

VS-8E2TL06-E, VS-8E2TL06-M, VS-8E2TL06FP-E



Vishay Semiconductors Ultralow V_F Ultrafast Rectifier,
8 A FRED Pt[®]

ORDERING INFORMATION TABLE

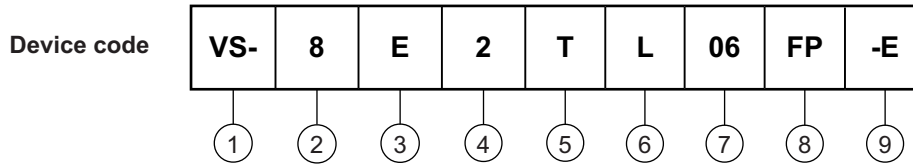

- 1** - Vishay Semiconductors product suffix
- 2** - Current rating (8 = 8 A)
- 3** - Circuit configuration:
E = Single diode
- 4** - 2 = True 2 pin package
- 5** - T = TO-220
- 6** - L = Ultrafast recovery time
- 7** - Voltage code (06 = 600 V)
- 8** -
 - None = TO-220
 - FP = FULL-PAK
- 9** - Environmental digit:
 - -E = RoHS compliant and terminations lead (Pb)-free
 - -M = Halogen-free, RoHS compliant and terminations lead (Pb)-free

ORDERING INFORMATION (Example)			
PREFERRED P/N	QUANTITY PER TUBE	MINIMUM ORDER QUANTITY	PACKAGING DESCRIPTION
VS-8E2TL06-E	50	1000	Antistatic plastic tubes
VS-8E2TL06-M	50	1000	Antistatic plastic tubes
VS-8E2TL06FP-E	50	1000	Antistatic plastic tubes

LINKS TO RELATED DOCUMENTS	
Dimensions	TO-220AC www.vishay.com/doc?95259
	TO-220 FULL-PAK www.vishay.com/doc?95260
Part marking information	TO-220AC www.vishay.com/doc?95391
	TO-220 FULL-PAK www.vishay.com/doc?95392
Packaging information	www.vishay.com/doc?95388



Disclaimer

All product specifications and data are subject to change without notice.

Vishay Intertechnology, Inc., its affiliates, agents, and employees, and all persons acting on its or their behalf (collectively, "Vishay"), disclaim any and all liability for any errors, inaccuracies or incompleteness contained herein or in any other disclosure relating to any product.

Vishay disclaims any and all liability arising out of the use or application of any product described herein or of any information provided herein to the maximum extent permitted by law. The product specifications do not expand or otherwise modify Vishay's terms and conditions of purchase, including but not limited to the warranty expressed therein, which apply to these products.

No license, express or implied, by estoppel or otherwise, to any intellectual property rights is granted by this document or by any conduct of Vishay.

The products shown herein are not designed for use in medical, life-saving, or life-sustaining applications unless otherwise expressly indicated. Customers using or selling Vishay products not expressly indicated for use in such applications do so entirely at their own risk and agree to fully indemnify Vishay for any damages arising or resulting from such use or sale. Please contact authorized Vishay personnel to obtain written terms and conditions regarding products designed for such applications.

Product names and markings noted herein may be trademarks of their respective owners.